

This is a linear plot of the same data as shown in the previous logarithmic plot. It is for AISI 4130, chrome-moly steel, normalized. It is easy to see where on this plot the fatigue limit can be found. Stressed to 30,000 psi, the tube will fail at one million cycles. The number of cycles to failure increases as the stress is reduced. Limit the stress to 20ksi and the fatigue life approaches infinity. The next step is to determine how much stress our bike is absorbing. Looking aft at a bottom bracket attached to the end of a seat tube cantilevered out from a frame such as was the case with the Clipper; we see that in this view, normal to the seat tube, the stress is about 17ksi.

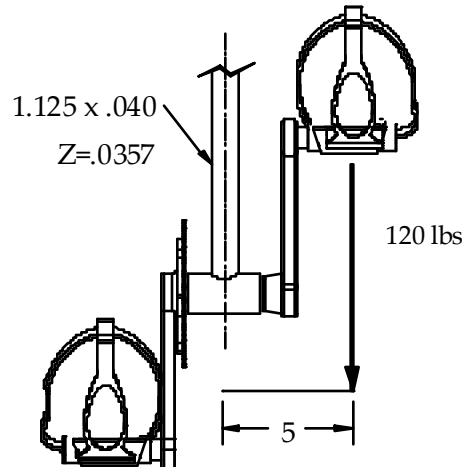

$$\text{BENDING MOMENT} = 5" \times 120\# = 600 \text{ IN-LBS}$$

$$\text{SEAT TUBE STRESS } M = Zf \quad 600\# = .0357f$$

Or: $f = M / Z$ Seat tube stress is 16,800 psi. Use this to predict fatigue life.